

Digital Automotive Pixel Link Receiver

INAP125R12
INAP125R24

The INAP125R12/24 is a receiver for the new Automotive **PIXel** (APIX) link for display and camera based point-to-point applications. The APIX link features an uni-directional pixel and full-duplex sideband data transmission over one single pair of shielded twisted pair (STP) copper cable. The upstream sideband can also be transmitted over a separate pair of wires to serve the requirements for automotive applications. In addition this wire may be used for power supply.

The INAP125R12 video interface supports color widths of 10 and 12bit, the INAP125R24 widths of 10, 12, 18 and 24bit. The interface can be configured individually to match all popular display and image sensor interfaces. The pixel interface features spread spectrum staggered outputs for lowest EMI.

The high-speed upstream outputs offer adjustable drive current to facilitate the adaptation to different link distances and cable qualities while offering maximum data integrity and full EMI compliance.

Packages:

- 52 pin QFN (Quad-Flat No-Leads)
- 64 pin QFN

Features:

- Up to 1 GBit/s Downstream Link
- Up to 62.5 MBit/s Upstream Link
- Low EMI, Two- or Four-Wire Full Duplex Link
- Spread spectrum staggered pixel interface
- +15 m Distance with low profile STP cables
- 10/12/18/24 bit pixel Interface
- Configurable sampling edge for pixel data
- DC-balanced line coding to support AC coupling
- Upstream nominal drive current configurable
- Optional equalizer functionality
- ISO10605 and IEC61000-4-2 compliant ESD protection
- Extended Temp. Range: -40 to +105°C
- AEC-Q100

Applications:

- Automotive Infotainment Displays
- Automotive Dashboard Displays
- Head-Up Displays
- Rear-Seat Entertainment Systems
- Automotive Driver Assistance
- Inspection Systems

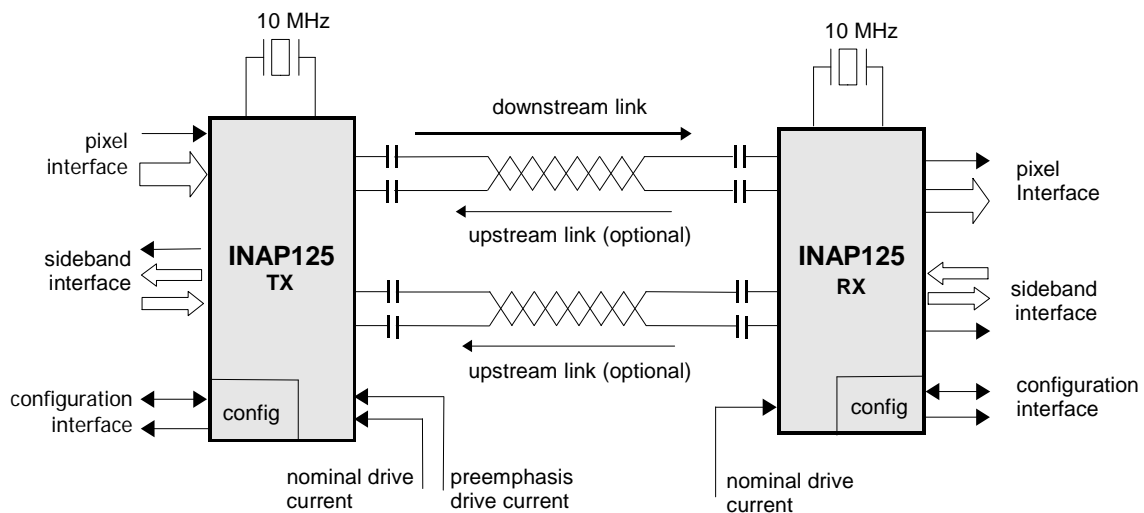

Figure 1: APIX system overview

1.0 Introduction

The APIX link transmits uncompressed pixel data with a sustained and resolution-independent link data rate of either 1 GBit/s or 500 MBit/s over one single pair of STP copper cable. In addition to the pixel data, bidirectional sideband control data can be transmitted over the same pair of wires.

The link supports distances of up to +15m (1 GBit/s mode) and up to +40m (500 MBit/s mode) depending on the output settings (current, pre-emphasis) and the cable properties.

Optimized for low EMI, the APIX link is dedicated for point-to-point applications within vehicles. The highly integrated architecture allows the implementation of video and audio links in applications like central information displays, dashboard and head-up displays, but also camera links as part of driver assistance systems requiring real-time digital video streams.

1.1 Transmission Channels

The APIX link provides three independent channels for data transfer

- the high speed downstream pixel channel
- the downstream sideband channel
- the upstream sideband channel

The pixel channel and the downstream sideband channel are multiplexed and commonly transmitted over the downstream link.

The upstream sideband channel can either be established over the same pair of wires as the downstream link (embedded upstream channel, see Figure 1-1) or alternatively over a separate pair of wires (Figure 1-2). The configuration needs to be performed by the configuration vectors (see section 3.1).

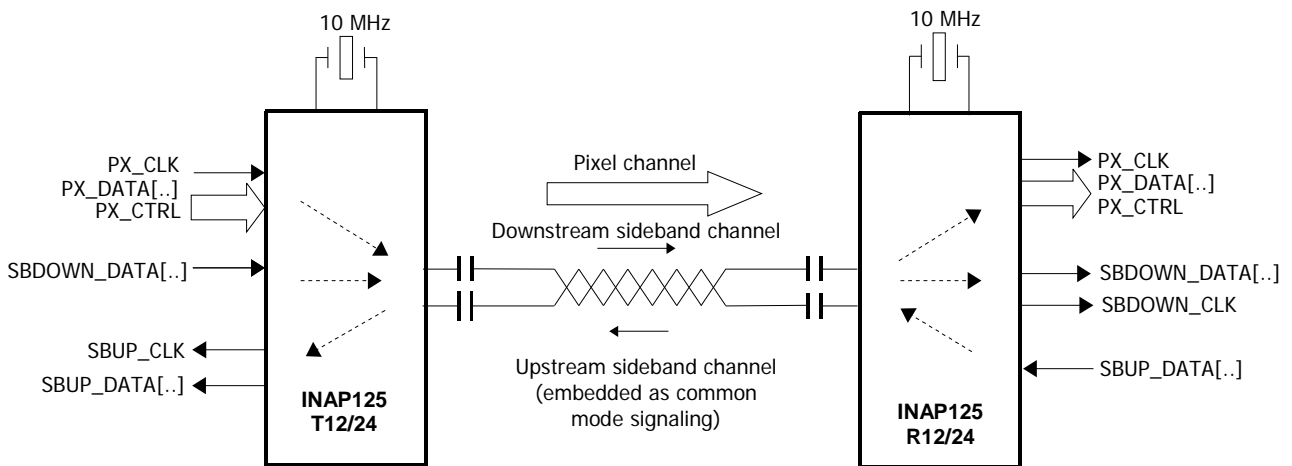

Figure 1-1: Single wire transmission channel configuration

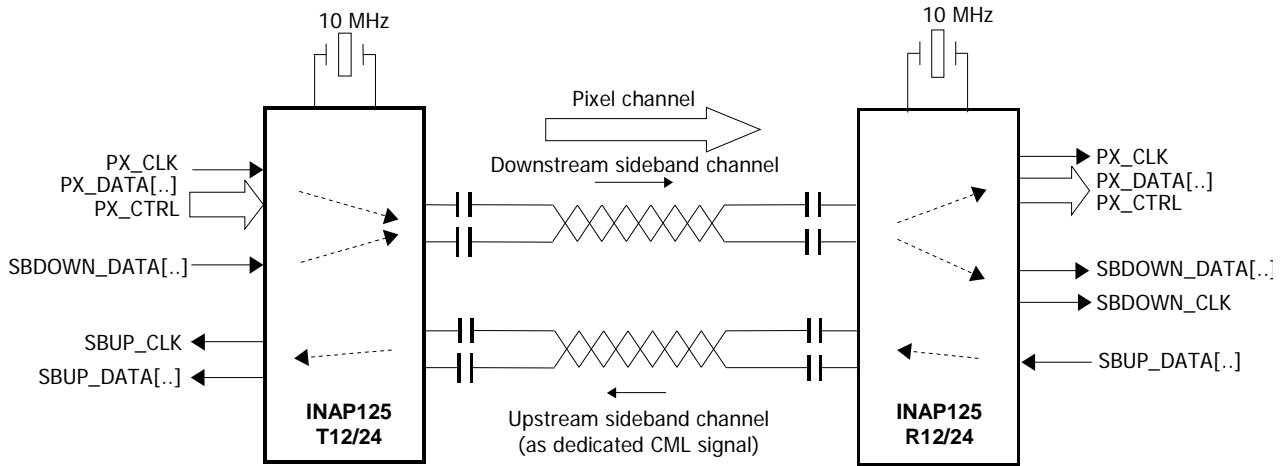

Figure 1-2: Two wire transmission channel configuration

1.2 Link Bandwidth

The bandwidth of the downstream link can be selected from these two modes:

- “full bandwidth” mode with a link data rate of 1 GBit/s, providing a net video data rate of 847MBit/s
- “half bandwidth” mode with a link data rate of 500 MBit/s, providing a net video data rate of 423.6MBit/s

The bandwidth also defines the maximum data rate possible for the sideband channels. The downstream sideband channel is transmitted in dedicated slots in the downstream link and therefore offers guaranteed low latency real-time characteristics. The maximum transmission rates is defined by the sampling frequency of the input pins as defined in section 2.3.2.

The upstream sideband channel is transmitted either as common mode signal on the same or as differential signal on a separate line (see Figure 1-2). The upstream channel data rate is configurable by configuration vectors as defined in section 3.1 and is not affected by the signalling method chosen for the upstream sideband channel.

2.0 Functional Description

2.1 Block Diagram

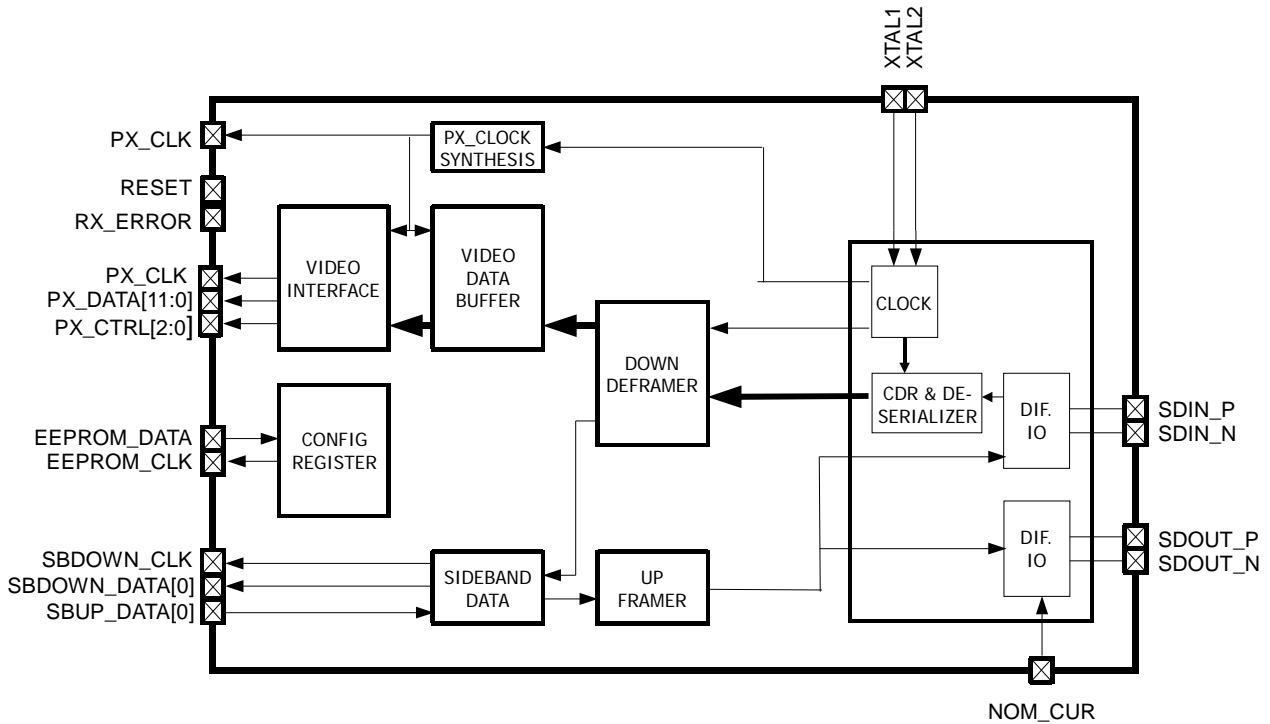

Figure 2-1: INAP125R12 Block Diagram

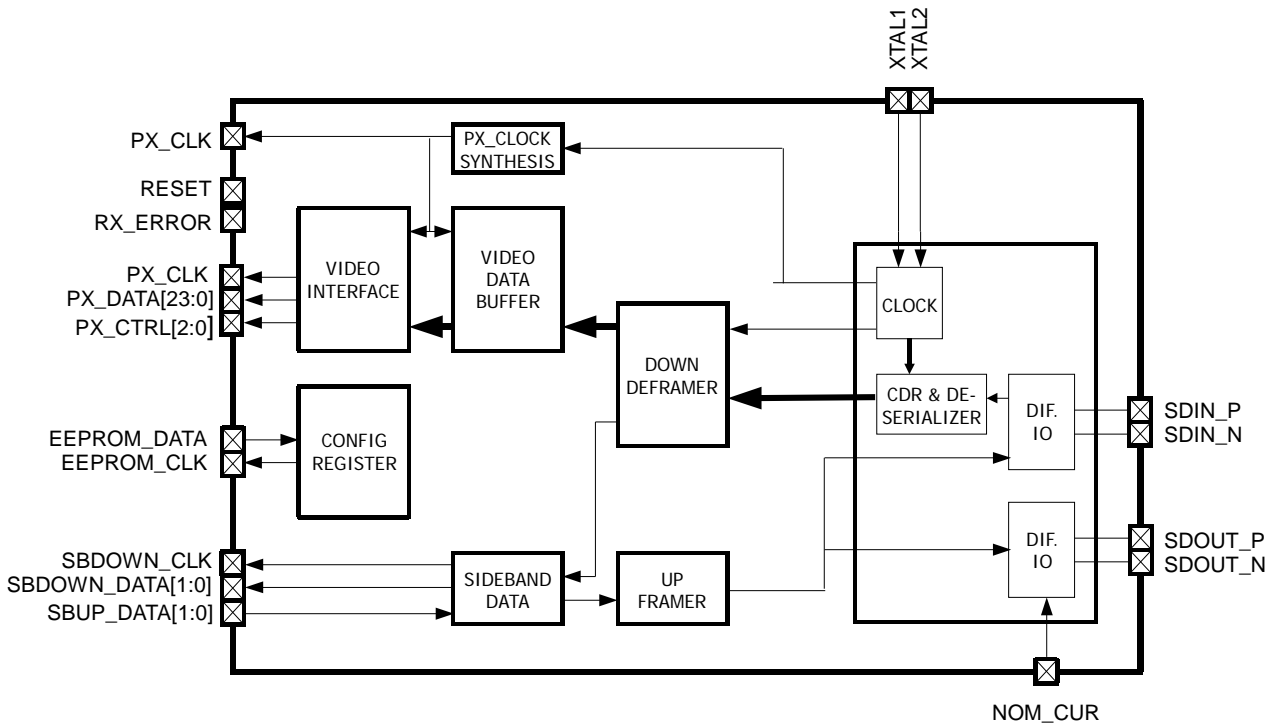

Figure 2-2: INAP125R24 Block Diagram

2.2 Serial Link Interfaces

2.2.1 Downstream Link Interface

The interface (SDIN+, SDIN-) of the downstream serial link (Tx -> Rx) is implemented with differential Current Mode Logic (CML).

2.2.2 Upstream Link Interface

As the upstream serial channel (from Rx to Tx) can alternatively be established over the downlink (embedded upstream channel) or a separate pair of STP cable, different signalling techniques will be employed. The selection of the mode is done by the configuration vectors (see section 3.1).

Option 1: Upstream and downstream channels share the same pair of STP cable. The upstream link employs common mode signalling technique.

Option 2: Upstream and downstream channels are transmitted over 2 separate pairs of STP cable. The additional upstream interface of the device (SDOUT+, SDOUT-) is realized with differential Current Mode Logic (CML).

2.3 Digital Interfaces

2.3.1 Pixel Data Interface

The pixel data interface is the output of the 24 bit parallel pixel data representing the video data. In addition 3 pixel control signals like HSYNC, VSYNC and DATA ENABLE can be transmitted. The interface provides the pixel data at PX_DATA[23:0] synchronous to the pixel clock at PX_CLK, which has a maximum of 62 Mhz as specified in Table 7-6. Data width and the configuration for the pixel control data are defined by configuration vectors (see section 3.1).

Channels	PX_DATA Width	control signal transmit mode configuration of transmission of pixel control signals		
		never	even pixels only	each pixel
Bandwidth mode 1GBit/s	10 bit	62.0 MHz	62.0 MHz	62.0 MHz
	12 bit	62.0 MHz	62.0 MHz	56.4 MHz
	18 bit	47.0 MHz	43.4 MHz	40.3 MHz
	24 bit	35.3 MHz	33.2 MHz	31.3 MHz
Bandwidth mode 500MBit/s	10 bit	42.3 MHz	36.8 MHz	32.5 MHz
	12 bit	35.2 MHz	31.3 MHz	28.2 MHz
	18 bit	23.5 MHz	21.7 MHz	20.1 MHz
	24 bit	17.6 MHz	16.6 MHz	15.6 MHz

Table 2-1: Maximum pixel clock frequency for different PX_CTRL and data width settings

The parallel pixel interface supports pixel formats of 10, 12, 18 and 24 bit, in combination with 3 control signals. Pixel data and control signals are provided synchronously with the pixel clock. In order to reduce switching noise and with this EMI, the pixel interface outputs are summarized into 4 groups, with three of them being

switched with different offsets to the pixel clock edge as shown in Figure 2-3. The offset time t_o has a typical value of 100ps, meeting the requirements for setup and hold times for the interface (see section 4.1.1), not affecting the overall pixel interface operation.

Color Depth	INAP125R12	INAP125R24
10 Bit	PX_DATA[9:0]	PX_DATA[9:0]
12 Bit	PX_DATA[11:0]	PX_DATA[11:0]
18 Bit	-	PX_DATA[17:0]
24 Bit	-	PX_DATA[23:0]

Table 2-2: Pixel data interface options

Control Function	INAP125R12	INAP125R24
HSYNC / lineSync	PX_CTRL[0]	PX_CTRL[0]
VSYNC / frameSync	PX_CTRL[1]	PX_CTRL[1]
DATA ENABLE / valid	PX_CTRL[2]	PX_CTRL[2]

Table 2-3: Pixel control interface

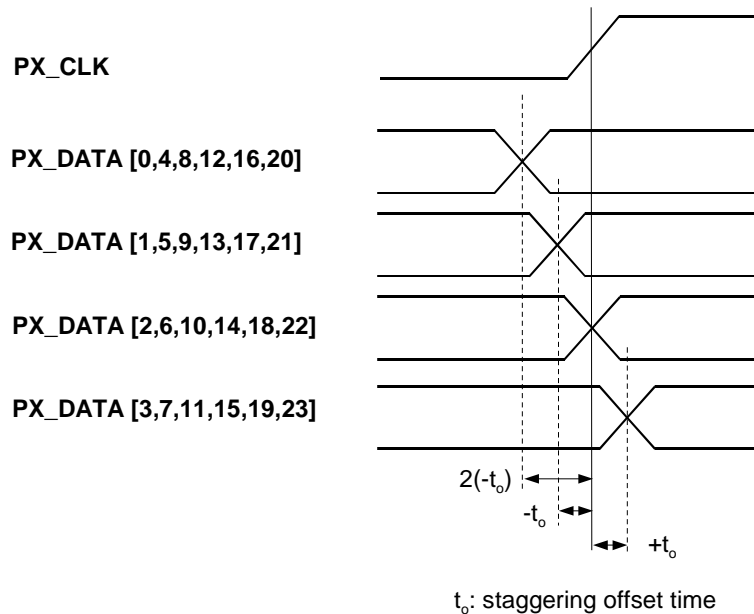

Figure 2-3: Staggered pixel interface outputs

2.3.2 Sideband Channel Downstream Interface

The sideband data downstream interface provides the sideband data at either one (INAP125R12) or two (INAP125R24) output pins. The pins are provided synchronously with SBDOWN_CLK, which reflects the downstream sample clock at the INAP125T12/24 receiver devices. The maximum data rate is limited by the downstream serial line clock, which is defined by a configuration vector (see Table 3-1). Please see Table 2-5 for a complete list of available data rates.

Downstream speed	Maximum Output data rate (per pin)	Output pins	
		INAP125R12	INAP125R24
1 GBit/s	<13.89 MBit/s	SBDOWN_DATA[0]	SBUP_DATA[1:0]
500 MBit/s	<6.94 MBit/s		

Table 2-4: Downstream sideband data rate with INAP125T12/24 transmitter

2.3.3 Sideband Channel Upstream Interface

The sideband data upstream interface provides either one (INAP125R12) or two (INAP125R24) input pins to sample sideband data at SBUP_DATA. Both pins are sampled at a specific internal frequency and transmitted as 2 bit data packet. The sampling frequency depends on the serial line clock mode selected for the upstream link and in general is defined to be 1/3 of the upstream serial line clock. Due to the framing structure of the upstream link, SBUP_DATA is not sampled every 16th clock cycle as shown in Figure 2-4.

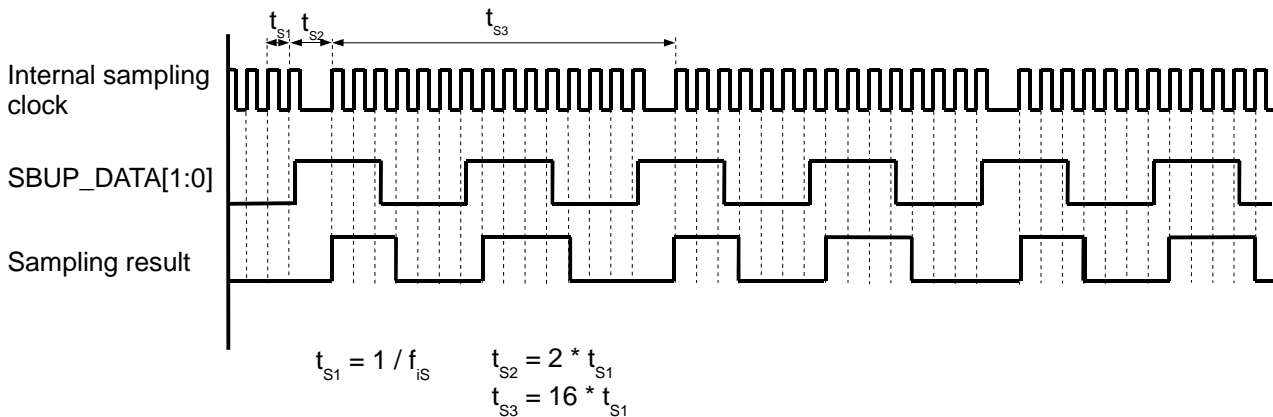

Figure 2-4: Asynchronous sampling of SBUP_DATA[1:0]

Upstream Serial Line Clock	internal sampling clock f_{is}	maximum sampling jitter	Input pins	
			INAP125R12	INAP125R24
62.5 MHz	20.83 MHz	104 ns	SBUP_DATA[0]	SBUP_DATA[1:0]
41.61 MHz	13.89 MHz	152 ns		
31.25 MHz	10.41 MHz	200 ns		
20.83 MHz	6.94 MHz	304 ns		

Table 2-5: Upstream sideband pin sampling frequency

2.4 Signal Description

Signal Name	Pin #	Type	Description
PX_DATA[11:0]	14,1,13,12,11,10,9,8,7,4,3,2	OUT	Pixel data output, provided with respect to the rising or falling edge of PX_CLK.
PX_CLK	24	OUT	Pixel clock output
PX_CTRL[2:0]	15,16,17	OUT	Pixel control signals
SBDOWN_DATA[0]	26	OUT	Downstream sideband data
SBUP_DATA[0]	47	IN	Upstream sideband data
SBDOWN_CLK	51	OUT	Sideband channel downstream clock
RESET#	46	IN	Asynchronous reset (active low)
RX_ERROR	52	OUT	PX_CLK error, or down link sync error (active high)
EEPROM_DATA	20	IN/OUT	Configuration data, Pull-up recommended
EEPROM_CLK	21	OUT	Configuration clock, Pull-up recommended
XTAL_IN	43	IN	Oscillator input or reference clock input
XTAL_OUT	42	OUT	Oscillator output
PX_VCO_IN	28	IN	VCO for pixel clock generation - Input
PX_VCO_OUT	27	OUT	VCO for pixel clock generation - Output
NOM_CUR	37	PASSIV	Upstream channel: nominal current control

Table 2-6: INAP125R12 Pinout description, 52-pin QFN

Signal Name	Pin #	Type	Description
SDOUT+	38	OUT	CML serial data interface upstream. Interface to differential transmission line with Zdiff = 100 Ohm.
SDOUT-	37	OUT	
SDIN+	30	IN	CML serial data interface downstream. Interface to differential transmission line with Zdiff = 100
SDIN-	31	IN	
VCO_TUNE	36	IN	VCO loop filter tuning voltage
PFD_OUT	35	OUT	Current output for VCO loop filter
VDD_VCO	34	PWR	Regulated power supply for VCO 1.8 V, 7 mA
VDD	18,50	PWR	1.8 V core supply
DVDD	5,22	PWR	3.3 V I/O supply
VDDA	33	PWR	1.8 V analog supply
VDD_OSC	44	PWR	1.8 V oscillator supply
DVDD_OSC	40	PWR	3.3 V oscillator supply
VSS ^a	19,48	GND	Digital core ground
DVSS ^a	6,23,25	GND	Digital I/O ground
GND ^a	29	GND	Analog ground
VSS_OSC ^a	45	GND	Oscillator ground
DVSS_OSC ^a	41	GND	Oscillator I/O ground
NC	32,49		not connected

Table 2-6: INAP125R12 Pinout description, 52-pin QFN

a. All VSS, DVSS and GND pins should be connected as common ground

Signal Name	Pin #	Type	Description
PX_DATA[23:0]	35,34,33,64, 63,62,32,31, 18,17,16,15, 14,1,13,12, 11,10,9,8,7, 4,3,2	OUT	Pixel data output, provided with respect to the rising or falling edge of PX_CLK.
PX_CLK	28	OUT	Pixel clock output
PX_CTRL[2:0]	19,20,21	OUT	Pixel control signals
SBDOWN_DATA[1:0]	36,30	OUT	Downstream sideband data
SBUP_DATA[1:0]	57,56	IN	Upstream sideband data

Table 2-7: INAP125R24 Pinout description, 64-pin QFN

Signal Name	Pin #	Type	Description
SBDOWN_CLK	60	OUT	Sideband channel downstream clock
RESET#	55	IN	Asynchronous reset (active low)
RX_ERROR	61	OUT	PX_CLK error, or down link sync error (active high)
EEPROM_DATA	24	IN/OUT	Configuration data
EEPROM_CLK	25	OUT	Configuration clock
XTAL_IN	52	IN	Oscillator input or reference clock input
XTAL_OUT	51	OUT	Oscillator output
PX_VCO_IN	38	IN	VCO for pixel clock generation - Input
PX_VCO_OUT	37	OUT	VCO for pixel clock generation - Output
NOM_CUR	46	PASSIV	Upstream channel: nominal current control
SDOUT+	47	OUT	CML serial data interface upstream. Interface to differential transmission line with Zdiff = 100 Ohm.
SDOUT-	48	OUT	
SDIN+	40	IN	CML serial data interface downstream. Interface to differential transmission line with Zdiff = 100
SDIN-	41	IN	
VCO_TUNE	45	IN	VCO loop filter tuning voltage
PFD_OUT	44	OUT	Current output for VCO loop filter
VDD_VCO	43	PWR	Regulated power supply for VCO 1.8 V, 7 mA
VDD	22,59	PWR	1.8 V core supply, PI filter recommended
DVDD	5,26	PWR	3.3 V I/O supply, PI filter recommended
VDDA	42	PWR	1.8 V analog supply, PI filter recommended
VDD_OSC	53	PWR	1.8 V oscillator supply, PI filter recommended
DVDD_OSC	49	PWR	3.3 V oscillator supply, PI filter recommended
VSS ^a	23,58	GND	Digital core ground
DVSS ^a	6,27,29	GND	Digital I/O ground
GND ^a	39	GND	Analog ground
VSS_OSC ^a	54	GND	Oscillator ground
DVSS_OSC ^a	50	GND	Oscillator I/O ground

Table 2-7: INAP125R24 Pinout description, 64-pin QFN

a. All VSS, DVSS and GND pins should be connected as common ground

3.0 Configuration, Reset, Power-Up and Error Detection

3.1 Configuration

The device parameters and settings are configured through a two-wire serial interface which is compatible to the MicroChip MicroWire™ interface. After power-up or reset, the INAP125R12/24 expects a serial EEPROM at the interface EEPROM_DATA and EEPROM_CLK, to read in the configuration vectors. In case no EEPROM is used, the chip needs to be stimulated with the PROM_start and PROM_stop bytes as shown in Table 3-1. If the initialization fails the default values will be used. Please see section 3.1.2 for more details on the programming flow.

3.1.1 Configuration vectors

Address (hex)	Bit#	Parameter	Recommended value	Default value	Comment
00	7:0	PROM_start	10111101		PROM valid byte 0
01	0	reserved	1	1	
	1	pixel interface wake-up 1	0	0	0: force pixel interface to „0“until VCO is stable 1: pixel interface is always enabled
	2	equalizer	1	0	Serial line equalizer status 0: enabled 1: disabled
	3	dedicated upstream		1	0: disable 1: enable dedicated upstream link Note: in case bits 3 and 4 are set to ,1', the upstream channel is disabled
	4	embedded upstream		0	0: disable 1: enable embedded upstream link Note: in case bits 3 and 4 are set to ,1', the upstream channel is disabled
	5	reserved	0	0	
	6	bandwidth mode		1	0: 1 GBit/s mode 1: 500 MBit/s mode
	7	wait period after configuration	1	1	0: no delay 1: 50 ms delay after configuration to stabilize the PLL

Table 3-1: Configuration vectors

Address (hex)	Bit#	Parameter	Recommended value	Default value	Comment
02	1:0	pixel data width		00	selects the width of pixel data to be transmitted 00: 10 bit 01: 12 bit 10: 18 bit 11: 24 bit
	3:2	control signal transmit mode	11	11	transmission of pixel control signals 00: never 01: unused 10: on every second (even) pixels 11: on each pixel
	4	reserved	1	1	
	5	pixel clock active edge		1	0: falling edge 1: rising edge
	7:6	upstream serial link clock		01	See Table 3-2 and Table 3-3
03	0	reserved	0	0	
	1	pixel interface wake-up 2	0 ^a	0	PX_DATA and PX_CTRL start at the upper left corner 0: disable 1: enable
	2	pixel interface wake-up 3	0 ^a	0	PX_CLK starts at the upper left corner 0: disable 1: enable
	3	fault tolerant transmission	1	1	tolerates single bit errors within the timing window 0: disable 1: enable
	7:4	RXError config	0000	0000	
04	0	pll status	0	0	loss of PLL synchronization resets device 0: enable 1: disable
	7:1	reserved	1000110	0000110	

Table 3-1: Configuration vectors

Address (hex)	Bit#	Parameter	Recommended value	Default value	Comment
05	7:0	reserved	00000000	00000001	
06	7:0	reserved	00000000	00000000	
07	7:0	PROM_end	10011001		PROM valid byte 1

Table 3-1: Configuration vectors

a. The pixel interface wake-up function is an option for displays only. It requires a valid video timing with all three control signals

Bandwidth mode	Configuration Bit 7:6	Upstream serial line clock
1 Gbit/s	01	62.5 MHz
1 Gbit/s	10	41.67 MHz
1 Gbit/s	11	31.25 MHz

Table 3-2: Sideband upstream configuration for full bandwidth mode

Bandwidth mode	Configuration Bit 7:6	Upstream serial line clock
500 MBit/s	00	62.5 MHz
500 MBit/s	01	31.25 MHz
500 MBit/s	10	20.83 MHz

Table 3-3: Sideband upstream configuration for half bandwidth mode

Status	Configuration Byte 3, Bit 7:4	Comment
Video Link Status	0000	High indicates ,no valid video transmission'
Pixel clock status	0001	Low indicates successful lock on pixel clock
Link established	0010	High if serial link established
CTRL2 detected	0011	Interface synchronized to video timing

Table 3-4: RX Error pin configuration

Status	Configuration Byte 3, Bit 7:4	Comment
(reserved)	0100:0110	
Pixel buffer error	0111	Indicates that pixel buffer is full or empty
(reserved)	1000:1111	

Table 3-4: RX Error pin configuration

3.1.2 Configuration procedure

The configuration of the INAP125R12/24 is performed through the MicroWire™ compatible interface. In general, the configuration may be performed by connecting a standard EEPROM or by serving the data from a micro controller or FPGA. The INAP125R12/24 expects the configuration vector data in 8-bit data format. In case of invalid PROM_start or PROM_end bytes, the devices uses the default values.

Please see Figure 3-1 for the general communication flow.

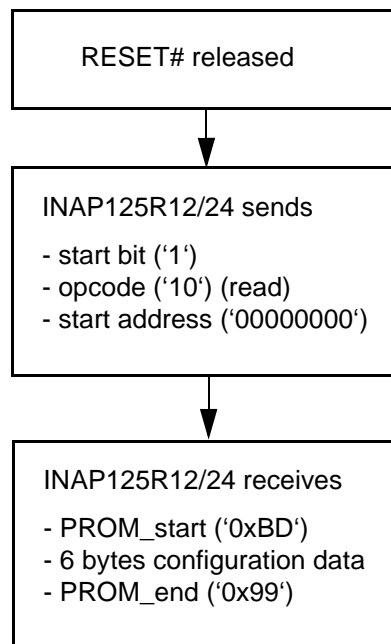

Figure 3-1: Configuration Flow

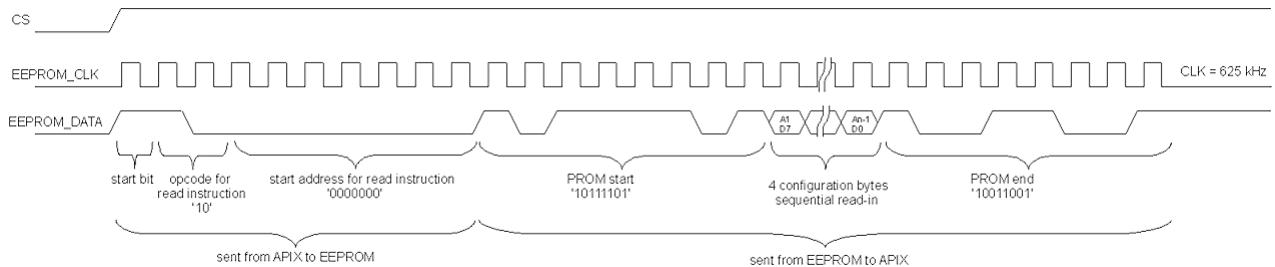

Figure 3-2: Configuration Interface Timing

Recommended EEPROMs are the 93L46A or 93L46C from Microchip Technology Inc. with selected word size of 8 bit. Since the INAP125R12/24 does not provide a dedicated CS signal, the EEPROM needs to support to send all data on just one rising edge of CS as shown in Figure 3-2. Please see Figure 3-3 for a typical connection circuitry for the EEPROM.

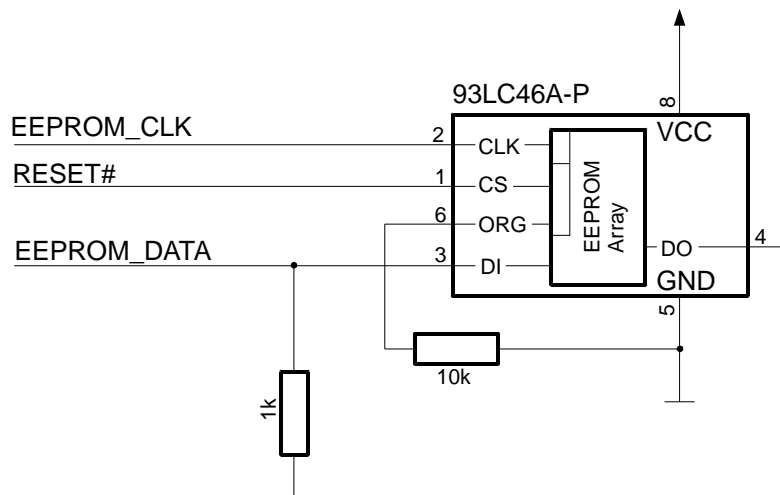

Figure 3-3: EEPROM connection circuitry

In order to connect the INAP125R12/24 configuration interface to the host controller, the host needs to be able to accept the interface clock from the APIX device.

Please note: The INAP125R12/24 is only able to respond to the PROM_Start and PROM_End command. No other Microwire commands supported.

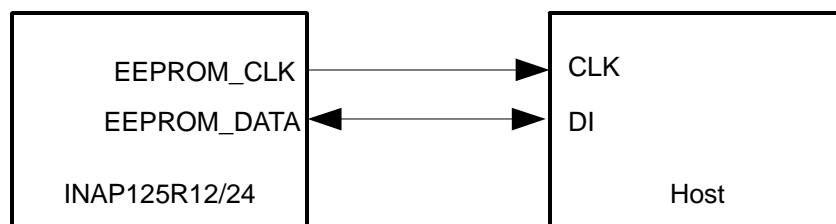

Figure 3-4: Host Connection diagram

3.2 Reset

The Reset pin triggers an asynchronous reset (active low) which can be activated at any time and sets the INAP125R12/24 into a defined state. The minimum low pulse width is four reference clock cycles.

During reset the serial output pins SDOUT-, SDOUT+ are held on VDDA level. All parallel outputs pins are at low level. EEPROM_DATA is set to Hi-Z.

3.3 Power-Up

3.3.1 Power-Up Sequence and Timing

The INAP125R12/24 power supplies do not require a specific power-up sequence. The device tolerates the supplies to be ramped simultaneously or in any order within the ramping time as defined in Table 3-5. Reset has to be held low until all supplies reached recommended operating conditions.

Supply	Ramp-Up time	
	Min	Max
All supplies	50µs	10ms

Table 3-5: Power supply ramping requirements

3.3.2 Power Supply Filtering

To achieve best transmission performance a noise level of less than 50mV on all analog and digital supply voltages VDD, VDDA, VDD_OSC, DVDD_OSC and DVDD is recommended. The loopfilter supply VDD_VCO requires lowest possible noise for best performance. See also section 6.0 for recommendations on power supply filtering.

3.4 Error detection

The INAP125R12/24 device includes an automatic error detection for the downstream transmission, which is indicated at pin RX_ERROR. The error status indicated by the pin is defined by a configuration vector as described in section 3.1.

4.0 Electrical Specification

4.1 Interface Timing

4.1.1 Pixel Interface

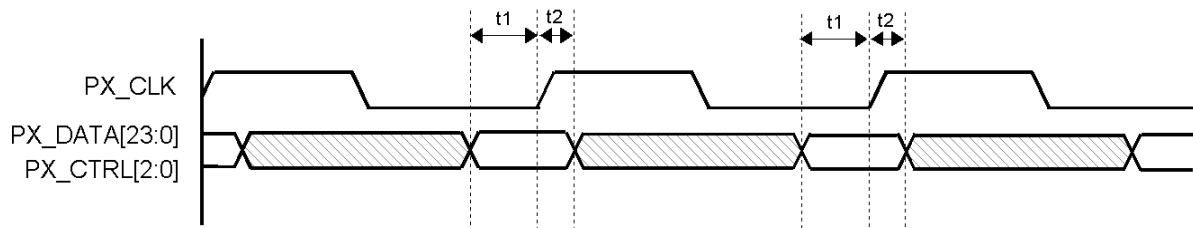

Figure 4-1: Pixel Interface timing at rising edge

Parameter	Description	Min.	Typ.	Max.	Unit
t_1	Pixel data and control signal setup time to pixel clock	2.6	3	3.5	ns
t_2	Pixel data and control signal hold time to pixel clock	1.8	2	2.5	ns

Table 4-1: Pixel interface timing at rising edge

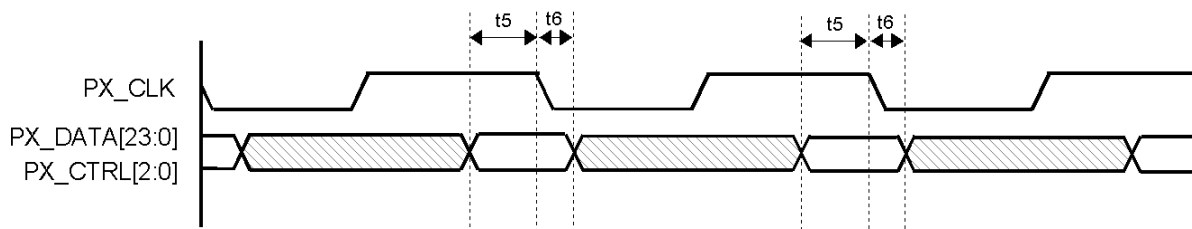

Figure 4-2: Pixel interface timing at falling edge

Parameter	Description	Min.	Typ.	Max.	Unit
t_5	Pixel data and control signal setup time to pixel clock	2.3	2.4	3	ns
t_6	Pixel data and control signal hold time to pixel clock	1.8	1.9	2	ns

Table 4-2: Pixel interface timing at falling edge

4.1.2 Sideband Interface Timing

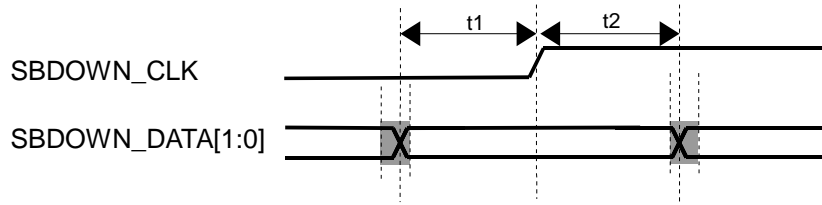

Figure 4-3: Downstream sideband Interface Timing

Parameter	Description	Min.	Typ.	Max.	Unit
t ₁	Sideband data setup time to sideband clock	-	6.5	-	ns
t ₂	Sideband data hold time to sideband clock	-	57	-	ns

Table 4-3: Downstream Sideband Interface Timing at 1Gbit/s bandwidth mode

Parameter	Description	Min.	Typ.	Max.	Unit
t ₁	Sideband data setup time to sideband clock	-	13	-	ns
t ₂	Sideband data hold time to sideband clock	-	114	-	ns

Table 4-4: Downstream Sideband Interface Timing at 500Mbit/s bandwidth mode

4.1.3 Configuration interface timing

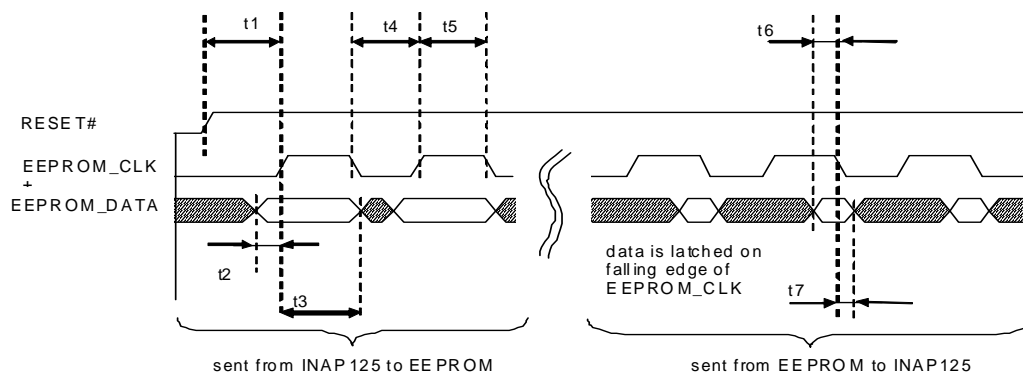

Figure 4-4: Configuration interface timing

Parameter	Description	Min.	Typ.	Max.	Unit
t ₁	RESET high to first EEPROM clk	6xt _{OSC} ^a	650	-	ns
t ₂	setup time EEPROM_DATA to EEPROM_CLK	-	400	-	ns
t ₃	hold time EEPROM_DATA to EEPROM_CLK	-	1200	-	ns
t ₄	EEPROM_CLK low time	-	800	-	ns
t ₅	EEPROM_CLK high time	-	800	-	ns
t ₆	setup time EEPROM_DATA to EEPROM_CLK	-	20	-	ns
t ₇	hold time EEPROM_DATA to EEPROM_CLK	-	10	-	ns

Table 4-5: Configuration interface timing

a. t_{OSC} reflects one clock cycle as defined by the external reference clock, see section 5.2.4

5.0 External circuits

5.1 External Termination Resistors

There are no external termination resistors required – for both Upstream and Downstream the dedicated 50 Ohm termination resistors are integrated in the circuit.

5.2 External Coupling Capacitors

5.2.1 Downstream Coupling Capacitors

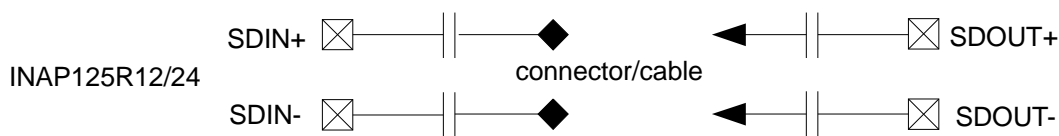

All capacitors: 100nF (X7R)

Figure 5-1: External coupling capacitors in downstream

5.2.2 Upstream Coupling Capacitors

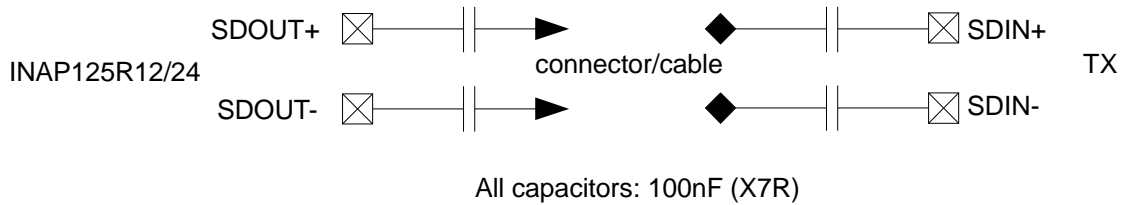

Figure 5-2: External coupling capacitors in upstream

5.2.3 External Loop Filter

5.2.3.1 System clock VCO

The INAP125R12/24 PLL circuit for the core system requires an external loopfilter which should be implemented as shown in Figure 5-3.

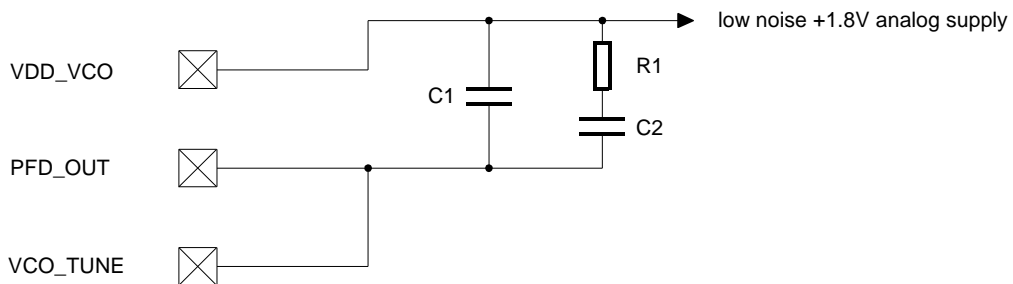

Figure 5-3: External loopfilter circuit for the system clock VCO

Symbol	Description	Value	Unit
C ₁	Capacitor C ₁	10	nF
C ₂	Capacitor C ₂	10	nF
R ₁	Resistor R ₁	100	kΩ

Table 5-1: Loop filter values for the system clock VCO

5.2.3.2 Pixel clock VCO

The INAP125R12/24 pixel clock recovery system requires an external loopfilter which should be implemented as shown in Figure 5-4.

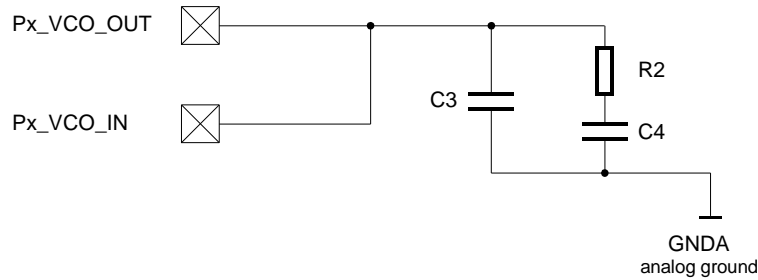

Figure 5-4: External Loop filter for the pixel clock VCO

Symbol	Description	Value	Unit
C ₃	Capacitor C ₃	2.2	nF
C ₄	Capacitor C ₄	47	nF
R ₂	Resistor R ₂	1	kΩ

Table 5-2: Loop filter values for the pixel clock VCO

5.2.4 External Reference Clock

The INAP125R12/24 core clock frequency is generated by an internal PLL controlled by an external 10 MHz crystal. Alternatively a stable 10 MHz clock signal (3.3V CMOS TTL) can be directly connected to XTAL_IN with XTAL_OUT left open. Figure 5-5 shows a typical crystal design required for the oscillator circuit. The values for C1, C2 and R1 need to be selected to match the oscillation requirements of the crystal Q1. Please see Table 5-3 for the external crystal.

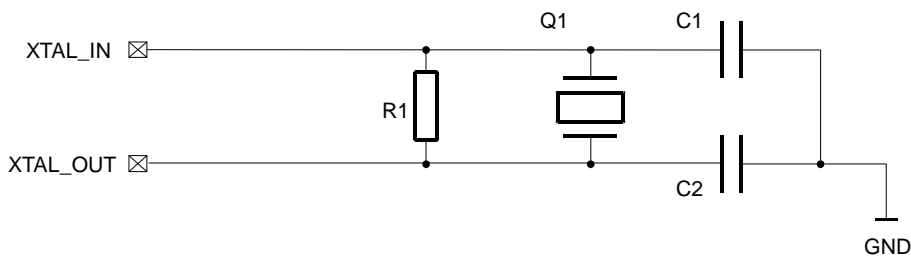

Figure 5-5: Crystal clock schematic example

Parameter	Symbol	Min	Typ	Max	Unit
Nominal Frequency	f_{osc}		10		MHz
Frequency Tolerance	F_{tol}	-100		+100	ppm
Equivalent Series Resistance	ESR			80	Ohm
Drive Level		see Table 5-4			

Table 5-3: Crystal requirements

For resonance at the correct frequency, the crystal needs to be loaded with its specified load capacitance C_L , which is the value of capacitance used in conjunction with the oscillation unit. The INAP125R12/24 oscillator provides some of the load with internal capacitance which is specified with in the range of 10pF to 12.5pF. The remainder is generated by the external capacitors and tuning capacitors labeled C1 and C2.

The load capacitance C_L can be calculated from $C_L = C_{int} + C1//C2$. E.g. selecting C1 and C2 with 15pF, C_L can be calculated to $C_L = 12.5pF + 7.5pF = 20pF$.

The crystal needs to be able to withstand the power dissipation, produced by the INAP125R12/24. The power dissipation depends on the ESR of the crystal and is reflected by the maximum drive level of the crystal. Table 5-4 illustrates the power dissipation of the INAP125R12/24 and therefore the minimum drive level capabilities of the crystal at different crystal ESR levels.

Crystal ESR	INAP125R12/24 Power dissipation / Minimum crystal drive level	Unit
30	77	μW
50	121	μW
80	179	μW

Table 5-4: Minimum Drive level vs. Crystal ESR

5.2.5 Nominal Upstream Current Control

To achieve optimum transmission of the upstream link, the signal swing of the INAP125R12/24 device can be adjusted by means of an external resistor. When using the embedded upstream channel, the resistor controls the swing amplitude. When using the external upstream link, the resistor adjusts the nominal drive current.

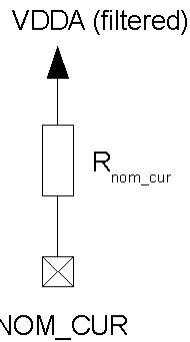
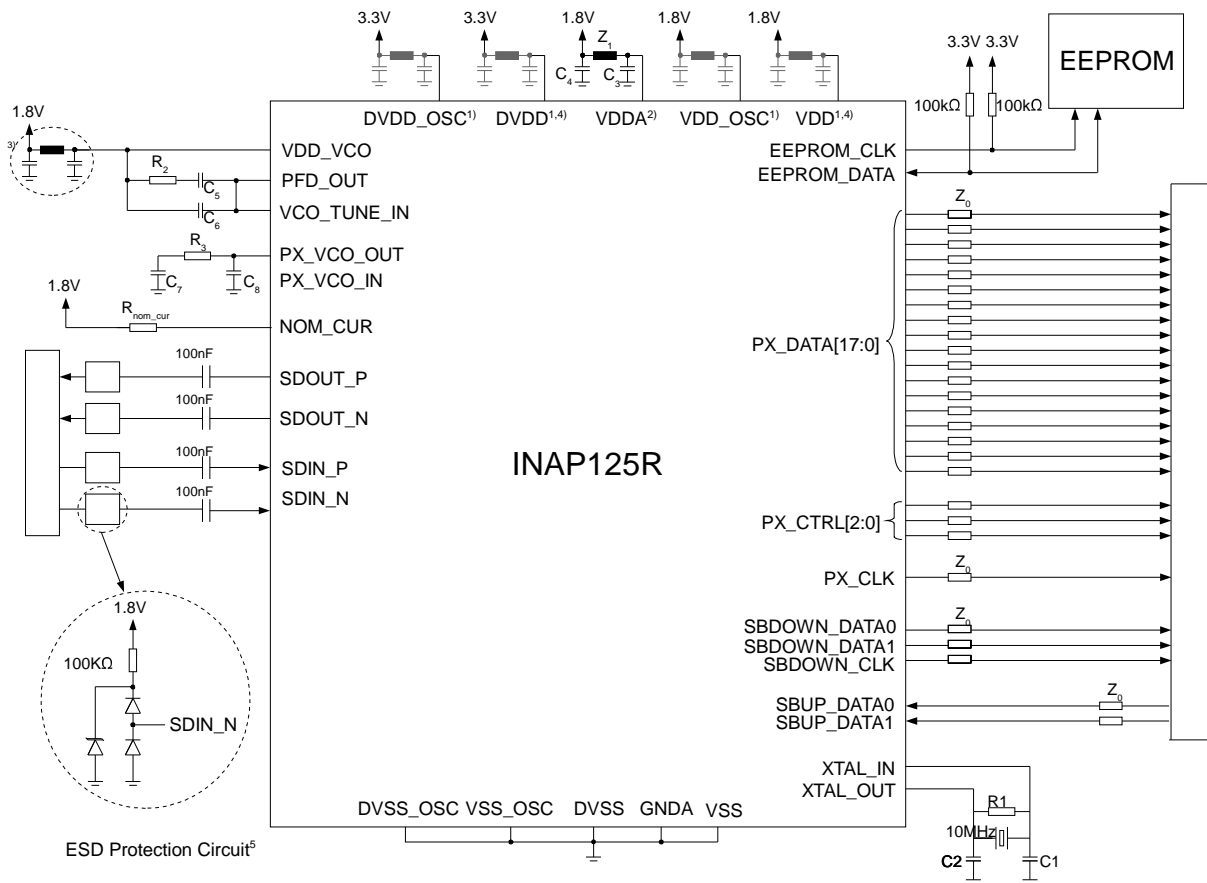

Figure 5-6: Nominal current

Symbol	Pin	Description	Min (recomm.)	Max (recomm.)	Unit
R _{nom_cur}	NOM_CUR	resistor value	500	10000	Ohm
		typ. add-on output current	0.5	5	mA

Table 5-5: Recommended component values for nominal current

6.0 Application example



- Z_0 : Trace impedance
- R1,C1,C2: Component values depend on selected crystal
- Z1,C3,C4: Filter design must be designed to eliminate oscillation on high dynamic currents with VDDA meeting specification requirements
- R2,C5,C6: Please check Table 5-1 for component values
- R3,C7,C8: Please check Table 5-2 for component values

- 1) Filter not required for functional reasons, but might be considered for EMI performance
- 2) Filter not required for functional reasons, but strongly recommended for EMI performance
- 3) Filter recommended for performance reasons
- 4) Filter recommended on all DVDD, VDD input pins, if required for EMI performance
- 5) ESD protection design implementation example, please check available circuitry

Figure 6-1: Application example

7.0 Electrical Characteristics

7.1 Absolute Maximum ratings

The absolute maximum ratings define values beyond which damage to the device may occur. Exposure to absolute maximum rating conditions for extended periods may affect device reliability. The functional operation of the device at these or any other conditions beyond the recommended operating ratings is not guaranteed.

Parameter	Symbol	Min.	Max.	Units	Note
DC Supply Voltage	V_{DVDD}, V_{DVDD_OSC}	-0.5	5.0	V	
Input Voltage	$V_{VDD}, V_{VDDA}, V_{VDD_OSC}$	-0.5	3.0	V	
I/O Current (DC or transient any pin)	I_D	-20	+20	mA	
Storage Temperature	T_{stg}	-55	+150	° C	
Max Soldering Temperature	T_{SLD} / T_{SLD}		260	° C	40 seconds maximum
ESD Protection IEC61000-4-2 Contact discharge ^a SDOUT+,SDOUT-,SDIN+,SDIN-		-8	+8	kV	$R_D=330\Omega, C_S=150pF$
ESD Protection IEC61000-4-2 Air discharge ^a SDOUT+,SDOUT-,SDIN+,SDIN-		-12	+12	kV	$R_D=330\Omega, C_S=150pF$
ESD Protection ISO10605 Contact discharge ^a SDOUT+,SDOUT-,SDIN+,SDIN-		-8	+8	kV	$R_D=2k\Omega, C_S=150pF$
ESD Protection ISO10605 Air discharge ^a SDOUT+,SDOUT-,SDIN+,SDIN-		-20	+20	kV	$R_D=2k\Omega, C_S=150pF$
ESD Protection HBM JEDEC JESD22/A114		-3	+3	kV	$R_D=1.5k\Omega, C_S=100pF$
ESD Protection CDM EIA/JEDEC JESD22/C101		-1	+1	kV	

Table 7-1: Absolute maximum ratings

a. ESD Protection values measured without external protection circuitry. Higher protection grades possible with external circuitry as described in section 6.0.

7.2 Recommended operating conditions

Parameter	Symbol	Min.	Typ.	Max.	Units	Note
Digital Core supply	V_{VDD}	1.71	1.8	1.89	V	
Analog supply	V_{VDDA}	1.71	1.8	1.89	V	
Oscillator supply	V_{VDD_OSC}	1.71	1.8	1.89	V	
Digital IO Supply	V_{DVDD}	2.97	3.3	3.63	V	
Oscillator supply	V_{DVDD_OSC}	2.97	3.3	3.63	V	
CML Current	I_{CML}	0.8		24	mA	Internal Current Source
Ambient Temperature	T_a	-40		+105	° C	

Table 7-2: Recommended operating conditions

7.3 DC Characteristics

under recommended operating conditions. Unused inputs should be tied to ground.

Parameter	Symbol	Test Condition	Min.	Typ.	Max.	Unit
CMOS Input High Voltage	V_{IH}	$V_{DVDD} = 3.3\text{ V}$	2.0		V_{DVDD}	V
CMOS Input Low Voltage	V_{IL}	$V_{DVDD} = 3.3\text{ V}$	0		0.8	V
CMOS Input High Current	I_{IH}	$V_{IN} = V_{DVDD}$	-10		10	μA
CMOS Input Low Current	I_{IL}	$V_{IN} = 0\text{ V}$	-15		-77	μA
CMOS Output High Voltage	V_{OH}	$I_{OH} = -4\text{ mA}$	2.4			V
CMOS Output Low Voltage	V_{OL}	$I_{OL} = 4\text{ mA}$			0.4	V
CMOS Output High Current	I_{OH}	$V_{OH} = 0.9 \times V_{DVDD}$			4	mA
CMOS Output Low Current	I_{OL}	$V_{OL} = 0.1 \times V_{DVDD}$			-4	mA
Power Dissipation Rx	$P_{\text{max_Rx}}$	max data transmission rate		180		mW

Table 7-3: DC characteristics

7.3.1 Supply Current

Parameter	min.	typ.	max.	Units
I_{vdd/vdd_osc}		10	13	mA
I_{vdda/vdd_vco}^a		71	95	mA
$I_{dvdd/dvdd_osc}$		6	8	mA

Table 7-4: Supply Current

a. values at maximum serial drive current NOM_CUR, configurable as described in section 5.2.5

7.4 AC-Characteristics

Parameter	Min.	Typ.	Max.	Units
Input Capacitance, any pin		3	5	pF
Serial Transmission Gross Data Rate (Downstream)	500	-	1000	MBit/s
Serial Transmission Gross Data Rate (Upstream)	20.8	-	62.5	MBit/s
CMOS Output Rise / Fall Time (CL = 10 pF)		5	10	ns

Table 7-5: AC-Characteristics

7.5 Pixel Clock Range

Parameter	Symbol	Min.	Typ.	Max.	Unit	Note
Pixel Clock Frequency	f _{PIX}	6		62	MHz	Maximum frequency depends on selected bit width

Table 7-6: Pixel Clock Range

8.0 Package Options / Ordering information

Device / Ordering Code	Description	Package	Minimum Order Quantity
INAP125R12	Rx w/10...12 bit Interface + 1 bit Sideband	QFN52	260 pcs/tray
INAP125R12-R2	Rx w/10...12 bit Interface + 1 bit Sideband	QFN52	2000 pcs/reel
INAP125R12-R4	Rx w/10...12 bit Interface + 1 bit Sideband	QFN52	4000 pcs/reel
INAP125R24	Rx w/10...24 bit Interface + 2 bit Sideband	QFN64	260 pcs/tray
INAP125R24-R2	Rx w/10...24 bit Interface + 2 bit Sideband	QFN64	2000 pcs/reel
INAP125R24-R4	Rx w/10...24 bit Interface + 2 bit Sideband	QFN64	4000 pcs/reel

Table 8-1: Package Options

8.1 RoHS compliance

The devices INAP125R12 and INAP125R24 are released as RoHS compliant.

9.0 Soldering information

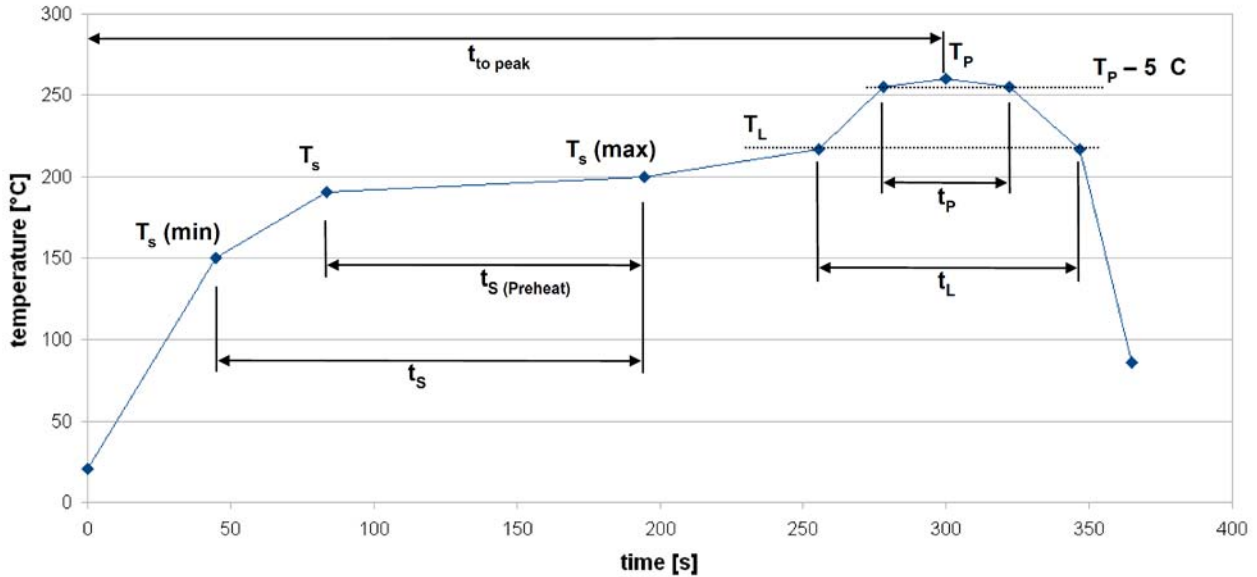

Figure 9-1: Reflow profile

Phase	Process parameter	target	unit
Pre-heat	ramp-up rate to 150°C (average value over 10s)	3	K/s
	T_s (min)	150	°C
	T_s	190	°C
	T_s (max)	200	°C
	t_s	150	s
	t_s (Pre-heat)	110	s
Peak	T_L	217	°C
	t_L = time above T_L	90	s
	T_P	260	°C
	t_p = time above $T_P - 5\text{ C}$	40	s
Cooling	Ramp-down rate from T_L (average value over 10s)	6	K/s
General	$t_{to\ peak}$	300	s
	number of soldering cycles	3	

Table 9-1: Reflow profile parameters

10.0 Package information

10.1 Pinout diagrams

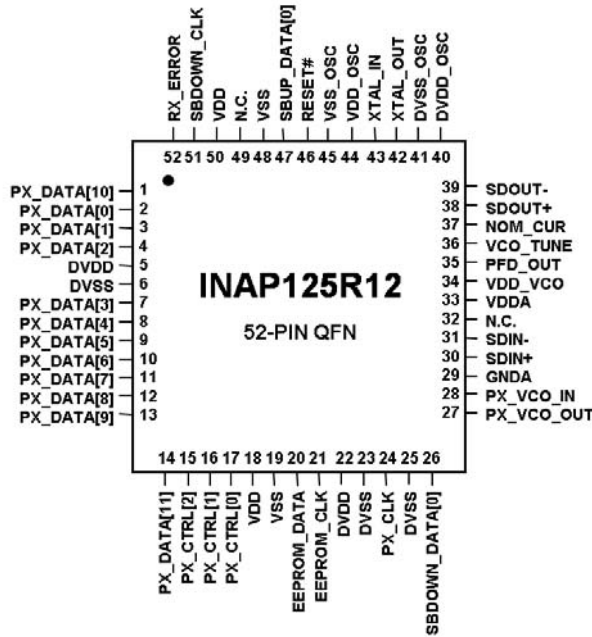

Figure 10-1: INAP125R12 pinout diagram

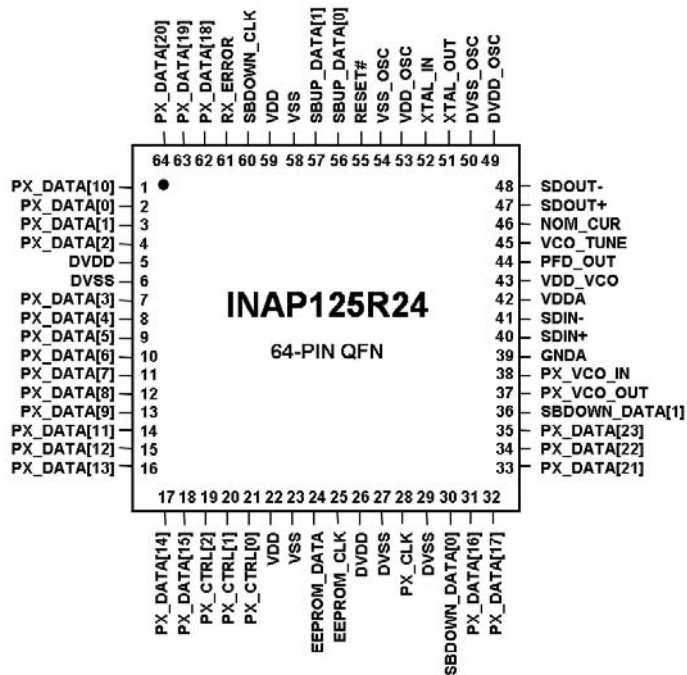

Figure 10-2: INAP125R24 pinout diagram

10.2 Package dimensions

all values in millimeter

10.2.1 52-pin QFN

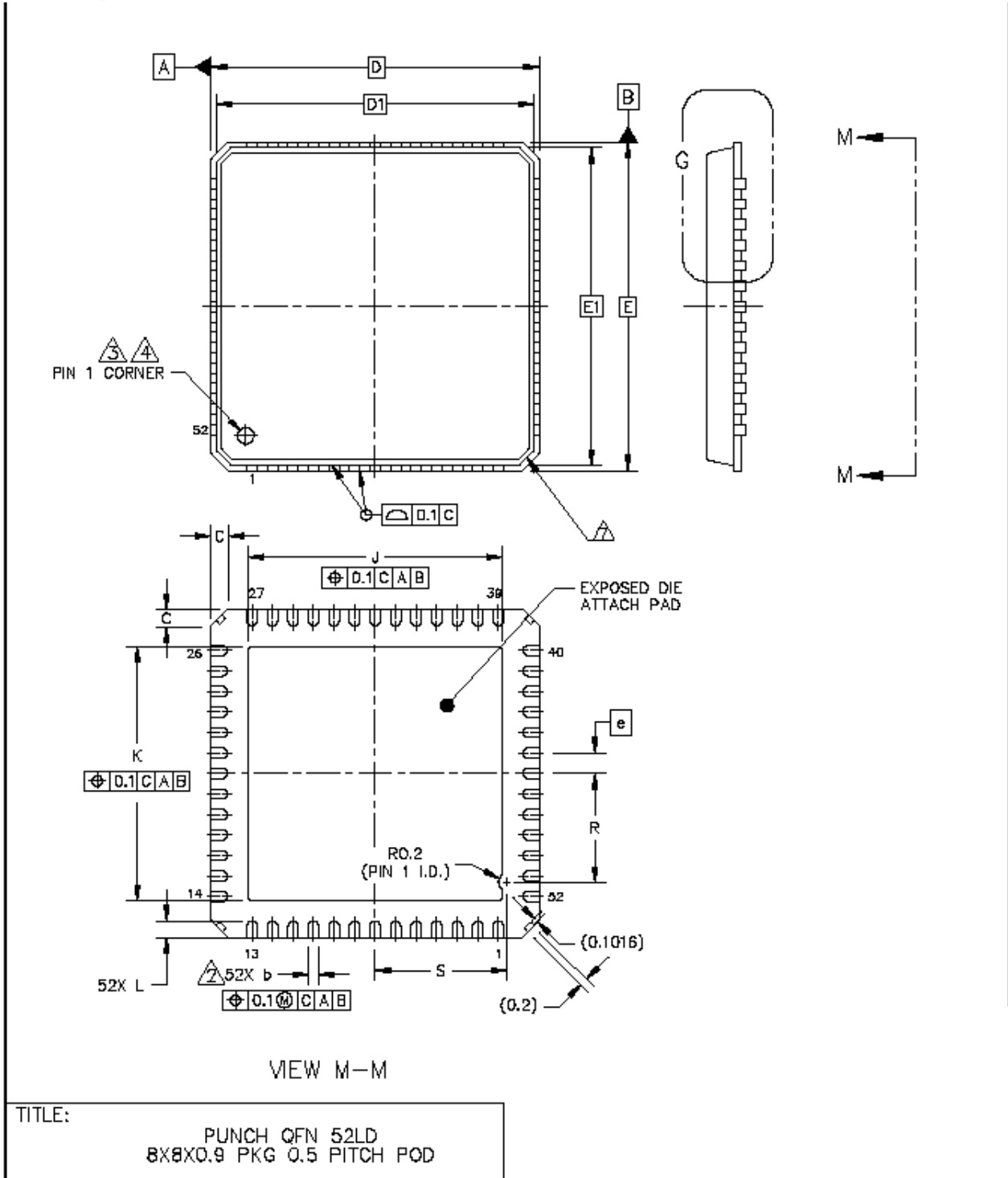
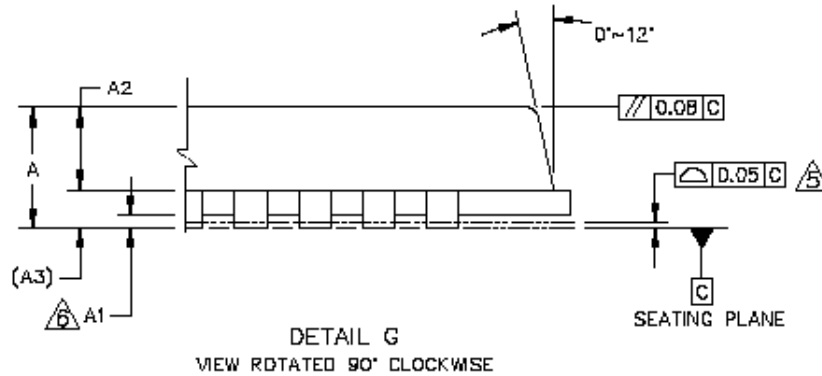

Figure 10-3: 52-pin QFN package dimensions



DIM	MIN	NOM	MAX	NOTES		
A	0.8		0.9	1. DIE THICKNESS ALLOWABLE IS 0.305mm MAXIMUM (.012 INCHES MAXIMUM) ⚠ DIMENSION APPLIES TO PLATED TERMINAL AND IS MEASURED BETWEEN 0.2 AND 0.25mm FROM TERMINAL TIP. ⚠ THE PIN #1 IDENTIFIER MUST BE PLACED ON THE TOP SURFACE OF THE PACKAGE BY USING INDENTATION MARK OR OTHER FEATURE OF PACKAGE BODY. ⚠ EXACT SHAPE AND SIZE OF THIS FEATURE IS OPTIONAL. ⚠ APPLIED FOR EXPOSED PAD AND TERMINALS. EXCLUDE EMBEDDING PART OF EXPOSED PAD FROM MEASURING. ⚠ APPLIED ONLY TO TERMINALS. ⚠ EXACT SHAPE OF EACH CORNER IS OPTIONAL.		
A1	0	0.02	0.05			
A2	0.65		0.69			
A3		0.203 REF				
b	0.18	0.25	0.3			
C	0.24	0.42	0.6			
D		8 BSC				
D1		7.75 BSC				
E		8 BSC				
E1		7.75 BSC				
e		0.5 BSC				
J	6.1	6.2	6.3			
K	6.1	6.2	6.3			
L	0.3	0.4	0.5			
R	2.55	2.65	2.75			
S	3.1	3.2	3.3			
				UNIT	DIMENSION AND TOLERANCES	REFERENCE DOCUMENT
				UNIT	ASME_Y14.5M	---
TITLE:				PUNCH QFN 52LD 8X8X0.9 PKG 0.5 PITCH POD		

Figure 10-4: 52-pin QFN package dimensions

10.2.2 64-pin QFN

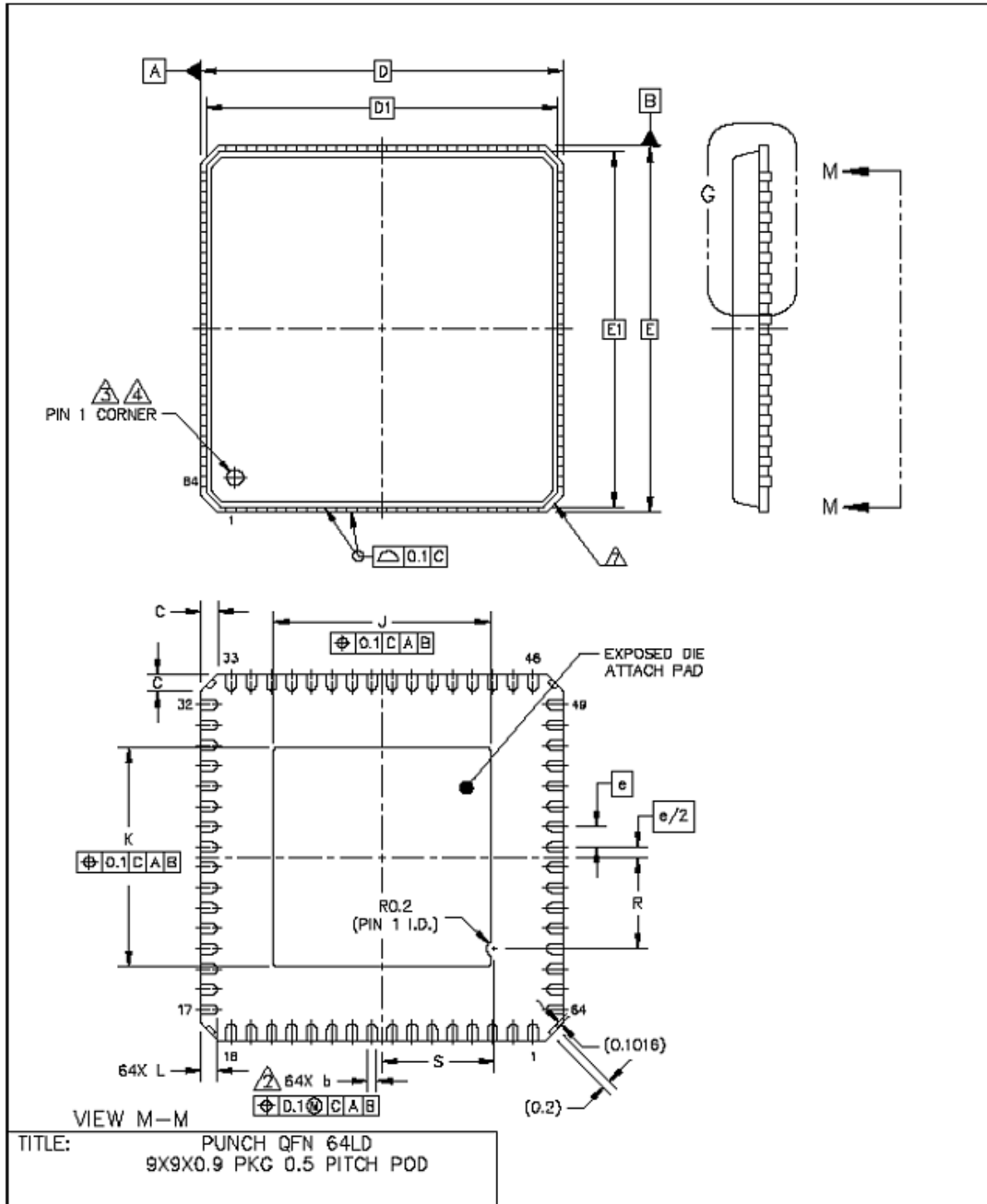
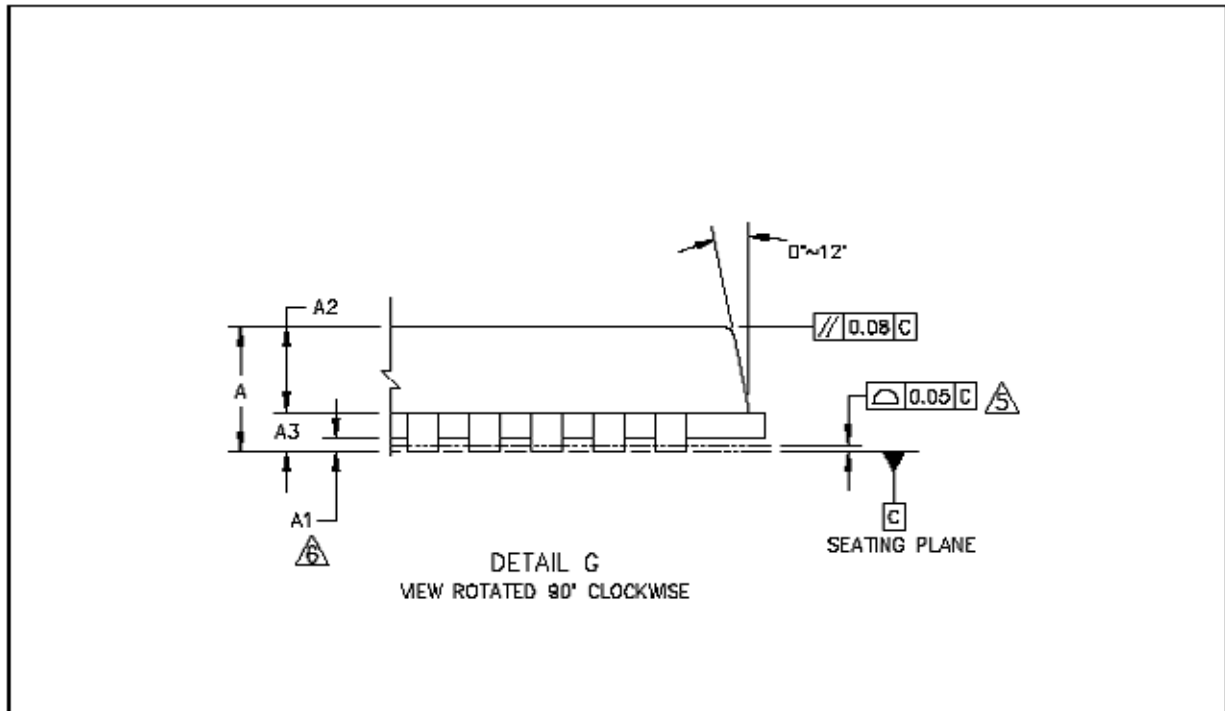

Figure 10-5: 64-pin QFN package dimensions



DIM	MIN	NOM	MAX	NOTES
A	0.8		0.9	1. DIE THICKNESS ALLOWABLE IS 0.305mm MAXIMUM (.012 INCHES MAXIMUM) ⚠ DIMENSION APPLIES TO PLATED TERMINAL AND IS MEASURED BETWEEN 0.2 AND 0.25mm FROM TERMINAL TIP. ⚠ THE PIN #1 IDENTIFIER MUST BE PLACED ON THE TOP SURFACE OF THE PACKAGE BY USING INDENTATION MARK OR OTHER FEATURE OF PACKAGE BODY. ⚠ EXACT SHAPE AND SIZE OF THIS FEATURE IS OPTIONAL. ⚠ APPLIED FOR EXPOSED PAD AND TERMINALS. EXCLUDE EMBEDDING PART OF EXPOSED PAD FROM MEASURING. ⚠ APPLIED ONLY TO TERMINALS. ⚠ EXACT SHAPE OF EACH CORNER IS OPTIONAL.
A1	0	0.02	0.05	
A2	0.65		0.69	
A3		0.203 REF		
b	0.18	0.25	0.3	
C	0.24	0.42	0.6	
D		9 BSC		
D1		8.75 BSC		
E		9 BSC		
E1		8.75 BSC		
e		0.5 BSC		
J	5.3	5.4	5.5	
K	5.3	5.4	5.5	
L	0.3	0.4	0.5	
R	2.15	2.25	2.35	
S	2.7	2.8	2.9	
		UNIT	DIMENSION AND TOLERANCES	
		UNIT	ASME_Y14.5M	---

TITLE: PUNCH QFN 64LD
9X9X0.9 PKG 0.5 PITCH POD

Figure 10-6: 64-pin QFN package dimensions

11.0 Revision History

Revision	Date	Changes
1.0	February 2008	Released Datasheet
1.1	December 2008	<ul style="list-style-type: none"> • Separated Transmitter and Receiver Datasheet • Various updates on general description and formatting • Renamed Pin SWING to pin NOM_CUR throughout the document • Added separate block diagrams for R12 and R24 • Updated Section "Pixel Data Interface" at page 5 • Updated Section "Sideband Channel Upstream Interface" at page 7 • Updated Table 2-6, "INAP125R12 Pinout description, 52-pin QFN," on page 8 • Updated Table 2-7, "INAP125R24 Pinout description, 64-pin QFN," on page 9 • Updated Section "Configuration vectors" at page 11 • Added Table 3-4, "RX Error pin configuration," on page 13 • Updated Section "External Reference Clock" at page 21 • Added Section "Application example" at page 24 • Updated Section "Electrical Characteristics" at page 25 • Added Section "Soldering information" at page 29
1.2	February 2009	<ul style="list-style-type: none"> • Updated V_{ESDCDM} to 1000V in Table 7-1, "Absolute maximum ratings," on page 25 • Corrected Default value of „Upstream serial line clock“ in Table 3-1, "Configuration vectors," on page 11
1.3	June 2009	<ul style="list-style-type: none"> • Added ESD protection values for ISO10605 and IEC61000-4-2 in Table 7-1, "Absolute maximum ratings," on page 25 • Added Figure 2-3, "Staggered pixel interface outputs" on page 6

Table 11-1: Revision History

Inova Semiconductors GmbH

Grafinger Str. 26

D-81671 Munich / Germany

Phone: +49 (0)89 / 45 74 75 - 60

Fax: +49 (0)89 / 45 74 75 - 88

Email: info@inova-semiconductors.de

URL: <http://www.inova-semiconductors.com>



is a registered trademark of Inova Semiconductors GmbH

All other trademarks or registered trademarks are the property of their respective holders.

Inova Semiconductors GmbH does not assume any liability arising out of the applications or use of the product described herein; nor does it convey any license under its patents, copyright rights or any rights of others.

Inova Semiconductors products are not designed, intended or authorized for use as components in systems to support or sustain life, or for any other application in which the failure of the product could create a situation where personal injury or death may occur. The information contained in this document is believed to be current and accurate as of the publication date. Inova Semiconductors GmbH reserves the right to make changes at any time in order to improve reliability, function or performance to supply the best product possible.

Inova Semiconductors GmbH assumes no obligation to correct any errors contained herein or to advise any user of this text of any correction if such be made.

© Inova Semiconductors 2009